

---

## PGA98D -- Cardioid Condenser Drum Microphone

---

### PG Alta Microphones

Congratulations on the purchase of a new Shure PG Alta series microphone. The PG Alta series delivers professional quality audio at an affordable price, with solutions for capturing nearly any source, including voice, acoustic instruments, drums, and amplified electric instruments. Suitable for live and studio applications, PG Alta microphones are built to last, and meet the same rigorous quality testing standards that make all Shure products trustworthy and reliable.

---

### General Rules for Use

- Do not cover any part of the microphone grille with your hand, as this will adversely affect microphone performance.
- Aim the microphone toward the desired sound source (such as the talker, singer, or instrument) and away from unwanted sources.
- Place the microphone as close as practical to the desired sound source.
- Work close to the microphone for extra bass response.
- Use only one microphone to pick up a single sound source.
- For better gain before feedback, use fewer microphones.
- Keep the distance between microphones at least three times the distance from each microphone to its source (“three to one rule”).
- Place microphones as far as possible from reflective surfaces.
- Add a windscreen when using the microphone outdoors.
- Avoid excessive handling to minimize pickup of mechanical noise and vibration.

### Applications

The small, flexible design of the PGA98D microphone allows it to fit into tight spots around drums. The included drum microphone clip makes drum mounting fast and easy, but the microphone can also be used on other sources by mounting it in a standard clip.

#### Drums

- For more stick attack, aim the microphone towards the center of the drum head.
- To capture more resonance and overtones, aim the microphone towards the edge of the drum head.
- Positioning the microphone closer to the drum head delivers increased bass.

## Other Instruments

The PGA98D can effectively capture other instruments where space is limited. Simply mount the microphone in a standard clip and adjust the gooseneck to aim it at the source.

---

## Drum Microphone Mounting

To attach the microphone clip to a drum rim:

1. Place the microphone clip with the groove seated securely over the top of the drum rim
2. Position the bottom of the clip to wrap underneath the drum rim. The clip is flexible and can be gently bent to fit if necessary.
3. Insert the microphone into the clip and adjust the gooseneck as necessary

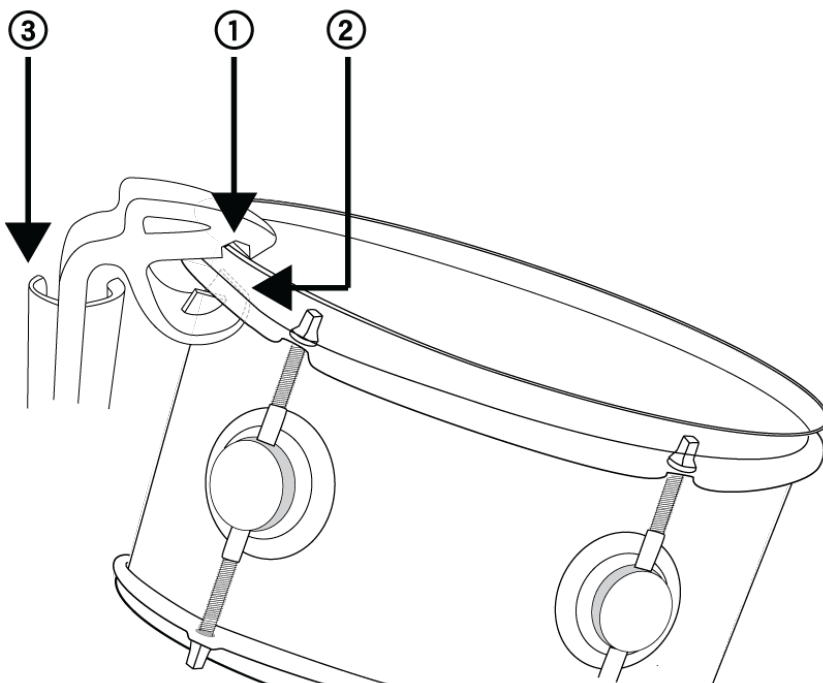

---

## Aiming the Microphone

Position the microphone with the arrow pointed at the sound source.



Front

---

## Specifications

**Type**

Electret Condenser

**Polar Pattern**

Cardioid

**Frequency Response**

60 to 20,000 Hz

**Output Impedance**

at 1 kHz, open circuit voltage

850  $\Omega$

**Sensitivity**

at 1 kHz, open circuit voltage

-52 dBV/Pa <sup>[1]</sup> (2.51 mV)

**Maximum SPL**

1 kHz at 1% THD, 1 k $\Omega$  load, typical

130 dB SPL

**Self Noise**

A-weighted, typical

27 dB SPL-A

**Polarity**

Positive pressure on diaphragm produces positive voltage on pin 2 with respect to pin 3

**Connector**

Three-pin professional audio (XLR), male

**Weight**

210 g (0.5 lbs)

**Housing**

Cast Zinc

**Power Requirements**

11 to 52 V DC phantom power (2 mA)

---

## Optional Accessories and Replacement Parts

Foam windscreen for PGA98H and PGA98D microphones	AP98WS
Drum mounting clip for PGA98D	AP98DM

---

## Certifications

This product meets the Essential Requirements of all relevant European directives and is eligible for CE marking.

The CE Declaration of Conformity can be obtained from: [www.shure.com/europe/compliance](http://www.shure.com/europe/compliance)

Authorized European representative:

Shure Europe GmbH

Headquarters Europe, Middle East & Africa

Department: EMEA Approval

Jakob-Dieffenbacher-Str. 12

75031 Eppingen, Germany

Phone: +49-7262-92 49 0

Fax: +49-7262-92 49 11 4

Email: [info@shure.de](mailto:info@shure.de)